

Data_Link 2000

APPLICATION NOTE AN018

Switching Inductive Loads

Summary

Micro_Link and *Nano_Link* have been subjected to independent external testing to confirm compliance with all relevant European Directives, including the EMC Directive. This means that they are immune to interference from external sources, provided all nearby equipment also complies with the EMC Directive. If any other equipment does not conform to the legal requirements and exceeds the limits set in the Directive it may cause *Micro_Link* or *Nano_Link* to fail.

Digital outputs from telemetry systems are often used to switch inductive loads such as interposing relays. When these are switched off very high voltages can be developed across them that cause arcing across the telemetry relay contacts. This in turn generates excessive levels of electromagnetic interference that can corrupt the electronics within the telemetry system. This application note explains the causes, the possible failure mechanisms and the method of overcoming the problem.

Introduction

A fundamental characteristic of any electrically inductive component is that it will attempt to maintain a constant current irrespective of the voltage across its terminals. For example, if a relay is energised by applying 24V across its coil via a switch, it might draw a current of 100mA, as illustrated in Fig 1:

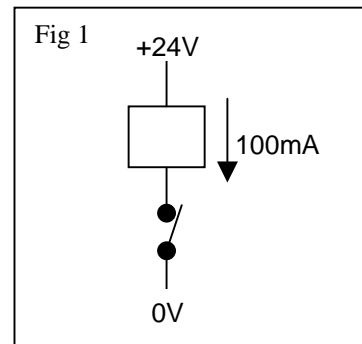

Energy is stored within the inductance of the coil that has to be dissipated when the switch opens. This has the effect of trying to maintain a current flow of 100mA, which will diminish to zero when the stored energy has been dissipated. The only way of maintaining the current flow is for the voltage across the open switch contacts to rise to the level at which an arc is drawn across them, which may require several hundred volts, as illustrated in Fig 2.

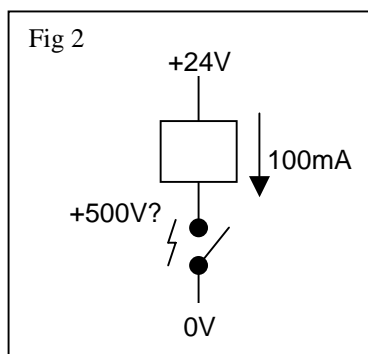

This causes two problems:

1. The arcing will erode the switch contacts, leading to eventual failure. Contacts designed to switch power loads are typically made of silver (which has a high melting point) to minimise erosion, but they will still eventually fail.
2. The arcing will generate electromagnetic radiation that could interfere with nearby electronic equipment. The source of the radiation is the arc, but the wires connecting the contacts to the relay coil and to 0V act as aerials to assist the radiation.

To prevent these problems an alternative route must be provided to safely dissipate the stored energy whilst clamping the voltage across the contact to a low level.

Digital outputs of telemetry systems can be used for a wide variety of applications, so the manufacturer cannot predict the voltage level or polarity that will be applied to them in normal use. There is thus a limit on the level of protection that can be incorporated into the product. The problem is exacerbated by the fact that in compact equipment the relays used to switch external loads are in close proximity with sensitive electronic components.

Micro_Link and *Nano_Link* digital output relays have bi-directional transient suppression diodes fitted across them to clamp the voltage to a maximum of 120V. This limits the maximum voltage that can be switched by the contacts, and also reduces, but does not eliminate, electromagnetic

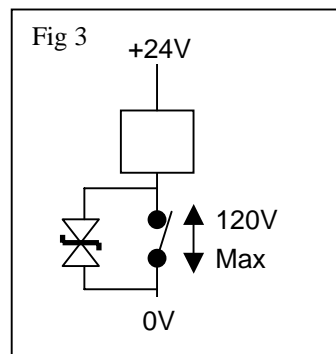

radiation from them.

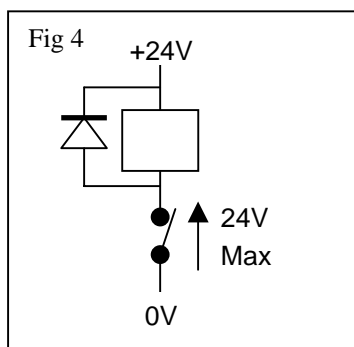

The preferred method of preventing the phenomenon is to fit a diode across each inductive load, as shown in Fig 4. When the switch is closed the diode has no effect, since it is reverse-biased across the 24V supply. When the switch opens the current that was flowing through it flows instead through the diode, hence clamping the voltage across the coil to typically 0.6V. The highest voltage ever present across the open switch contacts is thus equal to the supply voltage.

Diodes connected across inductive loads are given a variety of names, including 'flyback diodes', 'clamping diodes' and 'catching diodes'. Many manufacturers offer relays with built-in diodes, but they could alternatively

be fitted as discrete components connected externally across the coils.

It is obviously important to ensure that the diodes are connected with the correct polarity.

If inductive loads without diodes are connected to digital outputs of *Micro_Link* or *Nano_Link*, a variety of scenarios are possible:

1. If the inductance is sufficiently low the transient suppressor diodes built in to *Micro_Link* and *Nano_Link* may be sufficient to limit the radiation to levels that have no undesirable side effects.
2. The electromagnetic radiation from the relay contacts when they open can corrupt the internal microprocessor such that the software jumps to an invalid location, resulting in unpredictable actions. However, both *Micro_Link* and *Nano_Link* incorporate watchdog timers that reset the processors if the software fails to perform as intended. The interference may therefore cause an internal reset that will briefly switch off all digital outputs and set all analogue outputs to zero. This can obviously have potentially catastrophic consequences on any plant being controlled by the outputs.
3. The electromagnetic radiation may be sufficiently severe to cause a hardware latch-up. All integrated circuits incorporate parasitic diodes that are normally reverse-biased so have no effect. If any pin exceeds the rated voltage (e.g. due to electromagnetic radiation) one or more of these diodes may become forward-biased. In some cases the diodes can interact to create parasitic thyristors that latch into a conducting state. The only way of restoring normal operation is to cycle the power off and on.
4. In very severe cases the electromagnetic radiation may be high enough to cause irreversible damage to sensitive components.

It is important therefore to ensure that any inductive loads switched by telemetry digital outputs are protected using catching diodes. This applies equally to digital outputs from any other electronic equipment, such as PLC's.