

Data_Link 2000

APPLICATION NOTE AN017

Analogue Isolation Explained

Summary

Most analogue industrial instrumentation uses a universally-accepted 4...20mA interface signal. This makes it very easy to connect equipment from different suppliers, but the user should be aware of potential problems arising from earth loops and commoned signals, and the method of overcoming these.

Introduction

The 4...20mA analogue loop standard was evolved to allow a 2-wire connection to both power a transducer and read its output via a conventional ammeter. The simplified connection is as follows:

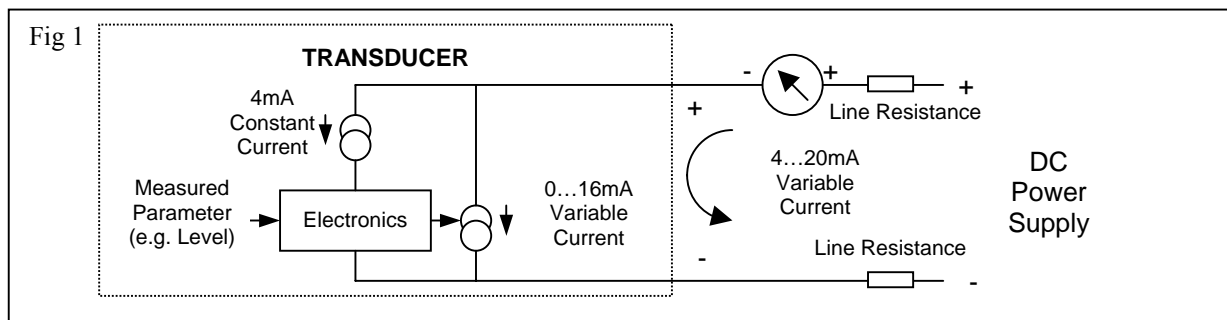

It should be apparent that the meter will read a fixed current of 4mA plus a variable current of 0...16mA which is proportional to the measured parameter. The electronics within the transducer must be designed to run from a constant current of 4mA, regardless of the voltage across its terminals. It will, however, have a minimum and maximum operating voltage, so the power supply must be chosen such that it doesn't exceed the maximum voltage rating, but it is high enough to maintain the minimum transducer voltage when 20mA is flowing through the meter and interconnecting cable. This is obviously influenced by the resistance of the meter and the connecting cable. For example, a typical transducer may be rated to operate from 5...32VDC. This defines that the power supply should typically be 24VDC. The maximum meter/cable resistance that can be tolerated is $(24 - 5)/20\text{mA}$, or 950Ω. It should be noted that multiple meters may be connected in series, and they can be in either the positive or the negative leg.

Note that both terminals of the meter and both terminals of the transducers are at unknown potentials, since neither is directly connected to the power supply, and there will be finite volt drops across the cable and meter. The same power supply can be used to power a number of transducer/meter combinations, but it is vital that there is no other electrical connection between them. This means that only one point can be connected to earth, and that is normally the negative side of the power supply.

However, problems arise if the transducer and/or meter are replaced by more complex electronic equipment such as telemetry systems or PLC's, since these have multiple analogue inputs and/or outputs that may be

commoned together on one side. The outputs (which emulate the transducer shown above) are almost invariably derived from electronics that sinks current to a common reference ^(SEE NOTE 1 BELOW).

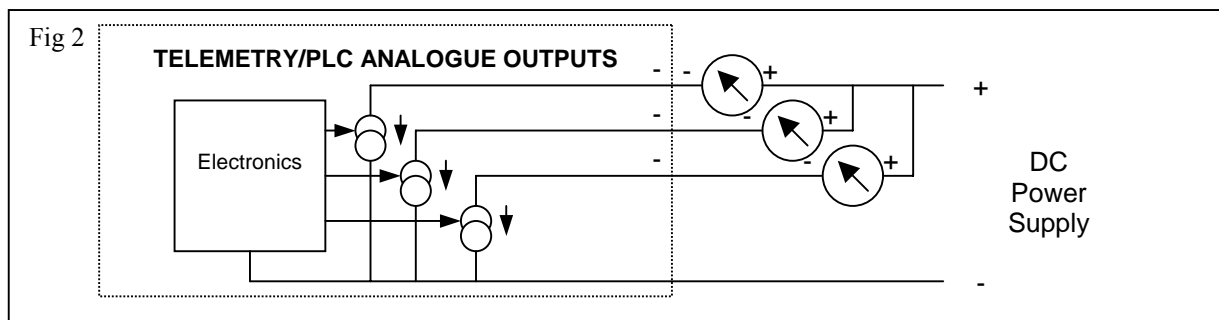

This circuit depends on the positive side of each meter being commoned to a positive supply. This supply could either be generated by the telemetry system or provided externally. As described above, the supply voltage must not exceed the maximum rating of the analogue outputs, but it must be high enough to maintain the minimum output requirements of the telemetry system (which may typically be 2V) when driving 20mA through the meter resistance. Note also that only the ‘-’ terminals of the analogue output are shown in this illustration. There will invariably be a ‘+’ terminal for each analogue output, but this will simply be the positive side of an internal power supply.

NOTE 1

Churchill Controls’ analogue output expansion modules incorporate a DC/DC converter on each channel to provide a fully isolated 24V power supply for each individual analogue. Outputs from these expansion modules can be connected to any type of analogue input.

Telemetry/PLC analogue inputs (which emulate the meter illustrated on page 1) are invariably designed with ‘floating’ inputs, so both input terminals can have a common-mode voltage superimposed on them. However, if the telemetry unit is designed to provide power to the transducers, one side of each input will be commoned to one side of the power supply. For example, the recommended connection for *Nano_Link* is as follows:

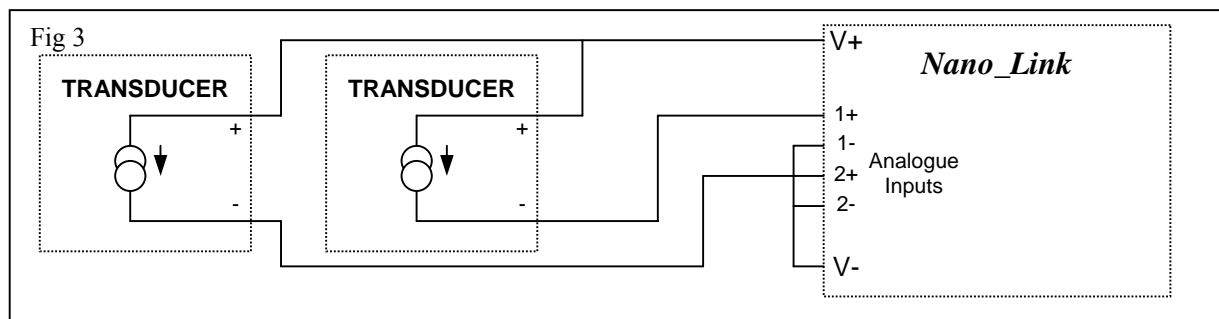

Nano_Link is optimised for battery operation, so the supply provided to energise transducers is 12VDC to avoid wasting power. The analogue input resistance is only 5Ω, so the transducers are supplied with an almost constant voltage of 12VDC, regardless of the current. If *Nano_Link* is used with transducers that require a higher operating voltage their positive sides can be connected to an external supply instead of V+, provided its negative terminal is connected to V-.

It should be apparent that the circuit shown in Fig 3 could not be used in conjunction with telemetry/PLC analogue outputs as illustrated in Fig 2, because the positives are commoned rather than the negatives.

However, if the circuit is changed as follows it is compatible with Telemetry/PLC analogue outputs:

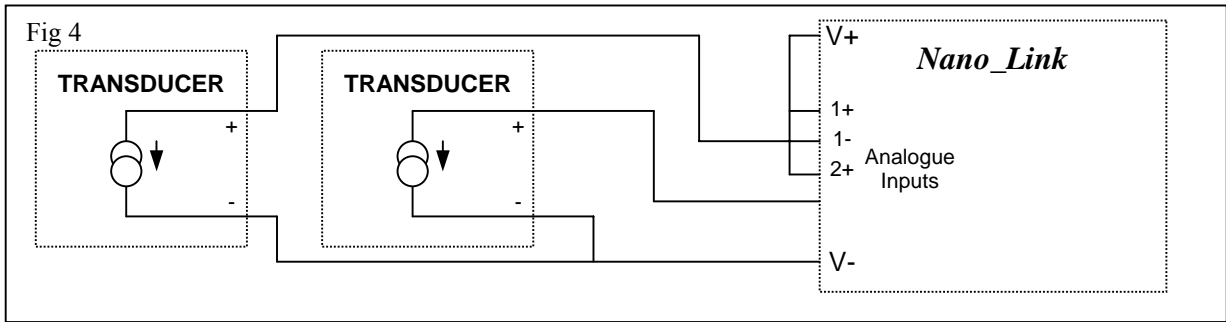

The *Nano_Link* is still providing power to each current loop, but now the negatives are commoned together.

Combining Fig 2 and Fig 4 shows how Telemetry/PLC analogue outputs can be connected to *Nano_Link* analogue inputs:

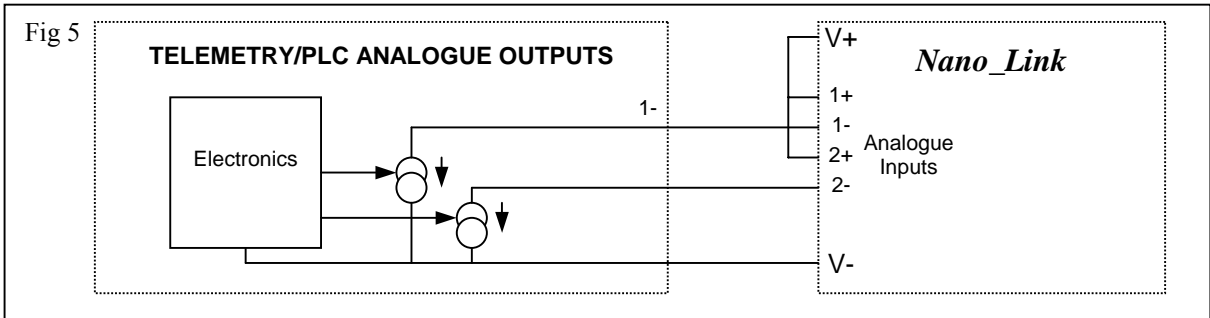

Nano_Link must be used to provide power to the current loops, and its negative side must be connected to the negative side of the Telemetry/PLC. If the '+' outputs of the Telemetry/PLC were used there is a risk that they could be higher than the *Nano_Link* supply and hence pull the *Nano_Link* analogue inputs above their designed operating range.

The ability of *Nano_Link* to accept analogue inputs commoned to either its positive supply or its negative supply is due to the fact that each input is a differential amplifier that detects only the difference in voltage between its '+' and '-' inputs, and disregards any common-mode voltage that may be present on both inputs *provided they remain within its common-mode input range*. The common mode input range of *Nano-Link* is V...V+, or 0...12VDC.

Outstations from some other manufacturers also employ differential amplifiers on their inputs, so allow common mode voltages within a specific range. These may allow the Telemetry/PLC to provide the positive return, but it must be within the common mode range. If this range is exceeded the analogues will be read incorrectly.

A more comprehensive method of providing analogue inputs is to use galvanic isolation. The most practical and accurate method is to use the flying capacitor technique, where each input has the following circuit:

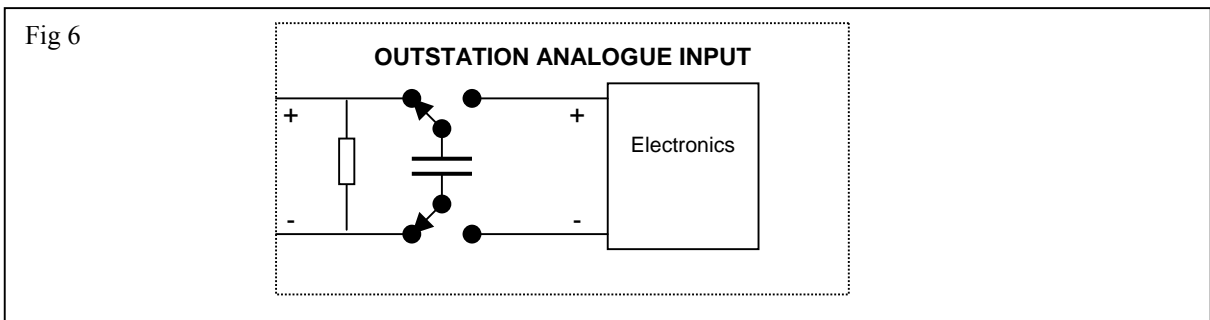

This uses 2-pole changeover relay contacts to switch a capacitor between the input terminals and the internal electronics. A resistor across the input terminals converts the current flowing through them to a voltage. When the relay is de-energised, the capacitor charges to this voltage. When it is energised the capacitor transfers the voltage to the internal electronics, whilst maintaining total isolation. This design can withstand several hundred volts of common mode signal, and is in fact only limited by the breakdown voltage necessary to cause spark-

over across the relay contacts. Multiple inputs can be multiplexed into a unit by duplicating the relays and capacitors.

This is the technique used on *Micro_Link* and Churchill Controls' analogue input expansion modules.

The following table summarises the techniques used for analogue inputs and outputs:

	Inputs	Outputs
<i>Nano_Link</i>	Differential amplifier, common mode range 0...12V	Current sink to 0V. Internal supply = 12V, but external supply of up to 32V can be used
<i>Micro_Link</i>	Isolated via flying capacitor. Max common mode voltage = 500V	Current sink to 0V. Internal supply = 12V, but external supply of up to 32V can be used
Churchill Controls' Expansion Modules	Isolated via flying capacitor. Max common mode voltage = 500V	Fully isolated outputs able to deliver up to 20V @ 20mA
Third party telemetry systems and PLC's	Usually differential amplifier, common mode range 0...24V, but check with supplier	Current sink to 0V. Usual internal supply = 12V or 24V, but check with supplier