

Wave Monitor Manual



Issue	Date	Revision
1	05/05/99	



This product is certified to comply with all relevant EU directives

© Churchill Controls Limited 2001

The contents of this document must not be disclosed to any third party without the written consent of Churchill Controls Limited, nor are they to be used for any purpose other than to configure and maintain equipment supplied by Churchill Controls Limited.

No part of this document can be reproduced, transmitted, transcribed, stored in a retrieval system or translated in any way without the prior written consent of Churchill Controls Limited.

Whilst every attempt has been made to ensure the accuracy of this document, Churchill Controls Limited will not be held liable for any errors or omissions.

As part of our policy of continuous improvement we would welcome any suggestions for changes to the document.

Churchill Controls Ltd.
Unit 2, Station Industrial Estate
Wokingham
Berkshire
RG41 2YQ
England

Tel: 0118 9892200
Fax: 0118 9892007
e-mail: sales@churchill-controls.co.uk
website: www.churchill-controls.co.uk

CONTENTS

1	SAFETY	4
2	GENERAL DESCRIPTION	4
3	CONTROLS AND SETTING UP PROCEDURE	5
3.1	CONNECTIONS	5
3.2	THE A.C. POWER SUPPLY MODULE	6
3.3	WAVE MONITOR MODULE	6
4	USE AND CARE OF THE PROBES	8
5	OPERATING ENVIRONMENT	8
6	CIRCUIT DETAILS	9
6.1	POWER SUPPLY MODULE	9
6.2	WAVE MONITOR MODULE	9
7	COMPONENTS LIST	14
7.1	WAVE MONITOR MODULE	14
7.2	POWER SUPPLY MODULE	16

1 SAFETY

The equipment has been designed to be compliant with EN60950.

The earth conductor for the equipment is the protective earth for the equipment. The conductor is connected to the module case. All module panels are earthed via an extended pin on the module connectors.

Only the mains cable supplied with the equipment should be used to make connection to the A.C. mains supply. The mains socket must incorporate an earth connection. If it is necessary to change the plug style on the supplied lead the replacement plug should be terminated as follows:-

L	Live	Brown wire
N	Neutral	Blue wire
E	Earth	Green/Yellow wire

The IEC connector on the rear of the case frame incorporates a 20mm mains fuse rated at 2 amps 'F'.

****** IMPORTANT ******

The power supply module supplied with this equipment is intended for operation on an A.C. mains supply 120V or 240V, 50-60Hz.

Before connecting the equipment to the A.C. mains supply unscrew the two captive retaining screws holding the power supply module in position. Select 120V or 240V operation on the p.c.b. selector switch. Re-insert the module into the frame. Screw the retaining screws to secure the module into position in the case.

2 GENERAL DESCRIPTION

The instrument is a simple robust device for the measurement and recording of water waves in hydraulic models and ship tanks. It works on the principle of measuring the current flowing in a probe which consists of a pair of parallel stainless steel wires. The probe is energised with a high frequency square wave voltage to avoid polarisation effects at the wire surfaces. The wires dip into the water and the current that flows between them is proportional to the depth of immersion. The current is sensed by an electronic circuit providing an output voltage proportional to the instantaneous depth of immersion, i.e. wave height, and can be used to drive a high speed chart recorder and/or data logger.

The standard form of probe supplied consists of a pair of stainless steel wires, 1.5mm in diameter and spaced 12.5mm apart. However the flexibility of the drive and sensing circuits enables a very wide variety of probe configurations to be employed. This versatility enables the user to construct probes to suit his own requirements, of which the following are a few examples.

Flat ribbon probes for high speed towing in ship tanks.

Long wires carried on either side of a support structure.

Specially shaped probes attached to the side of ship models for the measurement of pitch, heave etc..

The output voltage can be calibrated in terms of wave height by varying the depth of immersion of the probe in still water by a measured amount, and noting the change in output signal. A special probe support member with accurately spaced positioning holes is available to facilitate this operation.

The associated Wave Monitor Module carries the energisation and sensing circuits and means for compensating for the resistance of the probe connecting cable. It is powered from a separate Power Supply Module, A.C. mains operated, and with sufficient capacity to power 7 Wave Monitors.

When probes are used in close proximity to each other it is necessary for them to be energised at different frequencies to avoid mutual interaction. A plug and socket selector is provided on the Wave Monitor Module to enable the energisation frequency of each probe to be individually selected.

3 CONTROLS AND SETTING UP PROCEDURE

3.1 Connections

Before connecting the instrument to the power supply check that the correct Power Supply Module is present and that it is set for the correct voltage(120V or 240V).

A.C. mains is connected via the 3 pin plug at the rear. A 2 metre length of cable with a mating socket is provided.

Signal input and output connections may be made either by the sockets on the front panel or by the terminal blocks at the rear.

Connections to the rear terminal blocks are shown in Fig. 1 and the terminal block numbering matches the module socket pin numbering and is as follows:-

1. Voltage output (maximum + 10, 0, -10 volts).
2. Current output (maximum +10, 0, -10mA).
3. Galvanometer output (maximum +0.05 mA, 0, -0.05 mA).
4. Twin wire probe input.
5. Twin wire probe input.
7. Common (outputs only).

Instruments are supplied with the common line connected to chassis and to mains earth. If it is required to operate with the output signal isolated from earth it is necessary to remove the earth link between the white and green/yellow wires on the extreme left-hand module socket when viewed from the rear with the rear cover removed. In this case it is essential to connect the output signal via the rear terminal block.

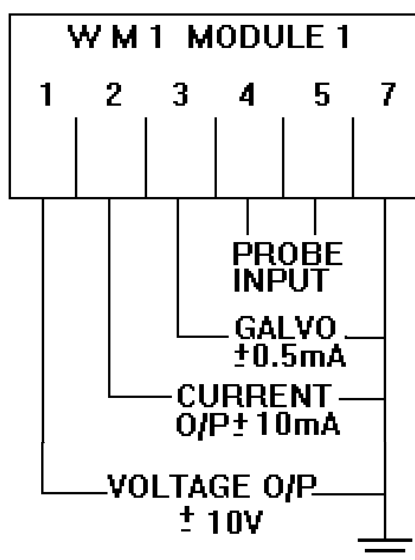

Fig. 1 Terminal Block Connections

3.2 The A.C. Power Supply Module

The unit is A.C. mains operated and provides regulated D.C. output voltages of +/-15V with a sufficient capacity to operate 7 Wave Monitor Modules.

MAINS VOLTAGE SELECTION

Mains voltage is selected by means of a switch on the Power Supply Module. Voltage may be set to either 240V or 120V A.C.

FUSE

2 amp rating. Located on rear mains connector.

LOCATION

The unit is located in the left hand position (when viewed from the front panel) of all instrument case assemblies. The rear plug connector is designed such that it will not engage in any other position.

3.3 Wave Monitor Module

There are two settings, one for the frequency and one for sensitivity made on the circuit card. For these the module must be withdrawn from the case.

FREQUENCY SELECTION

The energisation frequency of the probe is selected by inserting a jumper into one of a series of 6 card mounted pins. Each pin is labelled with the approximate frequency. When probe are used in close proximity to each other there is some advantage in operating the probe at the highest frequency to reduce the ripple content of the output signal.

SENSITIVITY SWITCH

The small jumper mounted in the circuit board alters the amplitude of the energisation voltage which is applied to the SET DATUM control. For probes up to 500mm in length the jumper should be set to position "S", i.e. with its jumper moved towards the front panel. For longer probes the jumper should be set to position "L", i.e. towards the rear plug connector to reduce the sensitivity of the SET DATUM control.

CONNECTION OF PROBE

The probe may be connected either to the red 4 mm sockets on the front panel by means of the plugs provided, or by means of terminal connections at the back. The connecting cable should be a twisted pair or a flat "figure 8". No special characteristics are required and a suitable cable would be one consisting of 2 conductors each 7/0.25mm (2 amp). The energisation voltage is balanced about earth so it is important that neither of the conductors is earthed.

LEAD COMPENSATION

The instrument incorporates means for compensation for the resistance of the connecting cable to ensure that a high degree of linearity of measurements is maintained over a very wide dynamic range of probe conductivity. Disconnect the probe cable at the probe end and insert the plugs into the blue TEST

sockets on the front panel. Depress the toggle switch into the TEST position, turn the SET OUTPUT control to its fully clockwise position, (i.e. maximum) and adjust the SET DATUM control until the pointer of the balance meter is in its central position (rotating the control clockwise raises the meter pointer). Depress the push button and rotate the COMP control with a screwdriver to restore the pointer to its balance position. Correct compensation is achieved when pressing and releasing the push-button results in no change in the position of the meter pointer. The plugs can then be removed from the TEST sockets and reconnected to the probe.

OUTPUT SIGNALS

The instrument provides an output signal with a centre zero at earth potential and with maximum excursions of + and - 10 volts. Connections can be made either to the OUTPUT coaxial plug on the front panel or by terminal connections at the rear where the following signals are available:-

Terminal 1: 10V; 0; -10V

Terminal 2: 10mA; 0; - 10mA from a source impedance of 1 K ohm.

Terminal 3: 0.05 mA; -0.05 mA with a parallel resistance of 240 ohms for galvanometer recorder. (Galvo. SMI/S).

The frequency response of the output signals is limited by the smoothing filter in the rectifier circuit which has a 95% response at 10Hz.

SET DATUM

This enables the output signal to be set to zero, i.e. to earth potential, for any initial depth of probe immersion. The instrument will then give its maximum full scale output of + and - 10 volts for waves which just reach the bottom of the probe in their troughs. To set up the control, fix the probe in position immersed to the required depth in still water, set the toggle switch on the front panel to the OPERATE position, set the SET OUTPUT control to its fully clockwise position, and then rotate the SET DATUM control to bring the indicating meter to its central position.

SET OUTPUT

This control attenuates the output signal and enables it to be set for a maximum voltage of any value between zero and 10 volts. Provided the datum has been adjusted as described in the previous paragraph the dial calibrations read directly in volts and/or milliamps. All that is required is to set the dial to required output and to lock it. Note that in doing so, the sensitivity of the datum adjustment and the cable resistance compensation described above is reduced, and it is recommended that this control always be set to its maximum before carrying out these operations.

CALIBRATION AND DATUM CHECK

An overall calibration from wave height to output voltage can be performed by noting the change in output voltage when the probe is raised and lowered by a known amount in still water. This operation is facilitated by means of the calibrated holder which has a series of holes drilled along its length accurately spaced at 10mm. The probe can be raised and lowered by a multiple of 10mm by using the pin provided as a stop. Once the calibration has been set and established the only further adjustment needed may be to trim the SET DATUM. If the electrical conductivity of the water changes for any reason, e.g. through changes in temperature there will be a resulting change in the instrument calibration. This can be re-adjusted by simply checking the setting of the datum by allowing the water to still, and verifying that the depth of probe immersion is the same as its initial conditions. If the indicating meter is slightly off

zero the balance can be restored by adjusting the SET DATUM control. No other adjustment is necessary.

BEAM FINDER

When the switch is in the operate position, the press button can be used to inject a small signal of approximately 10% of full scale, into the output signal. This will cause a small step to appear on the recorder deflection and can be used to identify the traces on the chart.

4 USE AND CARE OF THE PROBES

The instrument calibration is not markedly effected by distortion of the probe. No great accuracy is required in the wire spacing and provided the instrument is set up as described in the previous section, it is only necessary to ensure that gross distortion of the probe is avoided.

This type of probe is fairly insensitive to the electrical effect of deposits on the wires, but large accumulations of material affect the flow of water around them and should be removed. This can be done either by rubbing with very fine emery cloth or by dipping the probe wires into 2N hydrochloric acid, taking care that the acid is not allowed to come into contact with the electrical connectors.

Films of oil or grease on the wires have a serious detrimental effect and must be thoroughly removed. The probes should not be used in water having a film of oil on the surface.

The conductivity of the water changes with temperature (2% per deg.C approx.) and it is also dependent on the concentration of dissolved salts in the hydraulic model. In a new model, especially one moulded in cement mortar, the dissolved salt concentration can be very variable, both with time and with position in the model. It is therefore advisable to run waves in a new model for a few days before attempting to make any measurements. Regular checks on the probe calibration during this time will indicate when the dissolved salt content of the water is steady and uniform. This is particularly necessary if very long wave probes are to be used, because changes of salinity along the length of the probe will result in poor performance. Generally calibration checks need to be made twice daily, but probe calibration is a simple operation, being a single adjustment in still water because the probe has a linear response (see Section 3).

5 OPERATING ENVIRONMENT

Operating temperature range: 0 - 50°C.

Humidity: 95% non-condensing.

Mains Voltage: 240V or 120V (+6%, -10%), 50-60Hz.

The signal conditioning circuitry in the wave monitor module incorporates sensitive electronic circuitry. High electro-magnetic fields, such as those created by portable telephones, should be avoided when taking measurements. The highest frequency used in the circuit is 10kHz consequently there will be no unacceptable emissions from the equipment.

The IEC mains connector incorporates an RFI filter to provide protection from any RFI

filter to provide protection against RFI mains-borne interference which may affect calibration or measurements.

6 CIRCUIT DETAILS

6.1 Power Supply Module

The unit consists of 2 identical 15 Volt regulator circuits connected in series. The mains transformer has 2 tapped primary windings connected in series or parallel depending on the voltage supply. The secondary windings provide a nominal 18.8 volts r.m.s. which is rectified by the rectifiers REC 1 and REC 2. The unregulated D.C. voltage applied to the smoothing capacitors C1 and C2 should lie between the limits of 17 volts minimum and 30 volts maximum, if the mains voltage connections have been correctly selected. The regulators have internal fold back overload, thermal and short circuit protection and have a short circuit current of 230 mA.

The output voltage is not adjustable and should be $15V \pm 0.6V$.

6.2 Wave Monitor Module

The alternating voltage to drive the probe is produced by a square wave oscillator comprising the operational amplifier IC8. This produces a stable amplitude of 12 volts peak to peak determined by the zener diodes ZD1 and ZD2. The frequency is set by selecting one of the resistors R16 to R21 by means of the plug and socket arrangement on the circuit card. The range of frequencies covered is 5 KHz to 10 KHz in approximately 1 KHz steps. The oscillator output amplitude is controlled by the SET DATUM potentiometer VR2, for long probes (over 500mm) the conductivity of the probe is low, and requires a small drive voltage from the oscillator. In order to reduce the sensitivity of the setting of VR2, R15 is introduced in series with it by opening the switch S1.

The circuit diagram of one of the two probe drive amplifiers is shown separately in Fig. 2. In this simplified form it is easier to see how the amplifier operates. In the following description it is assumed that no common mode signals are present and that the two input amplifiers act as a balanced pair.

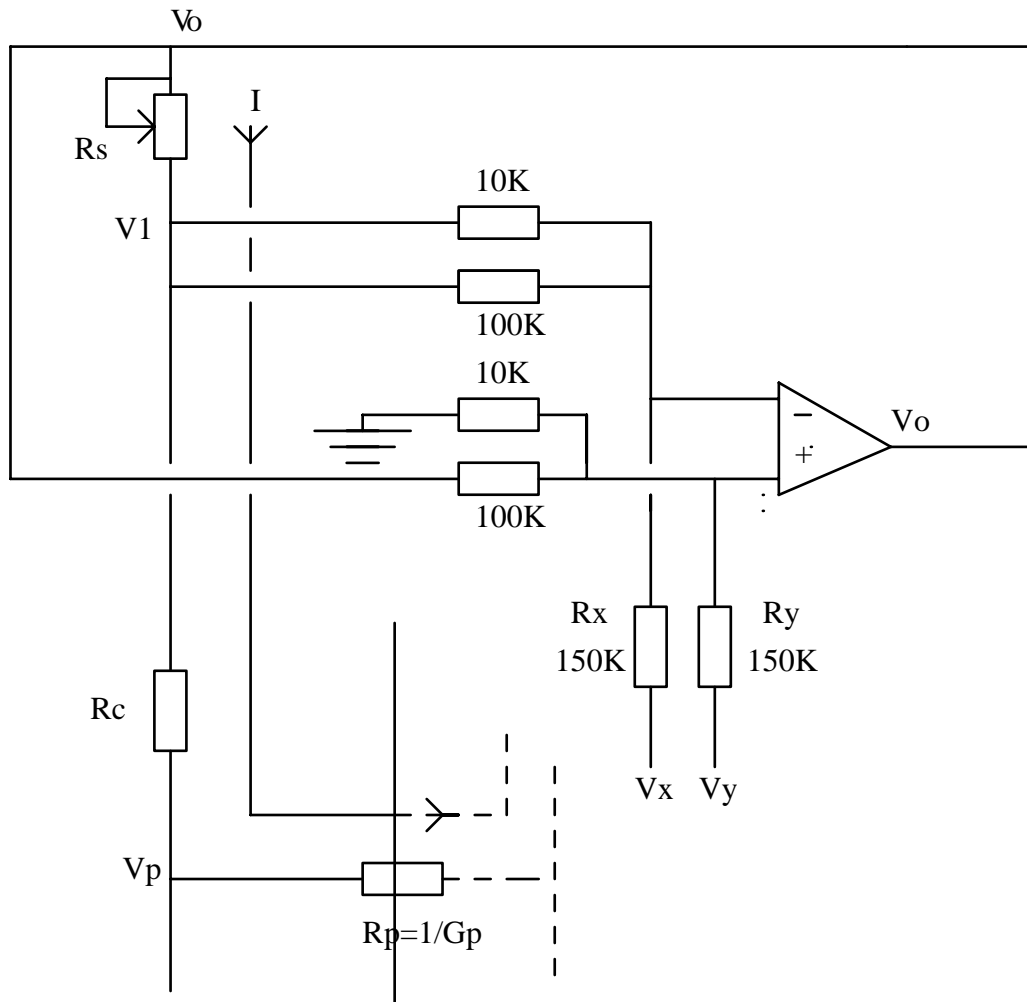

Fig 2. Probe Drive Amplifier

In the simplified diagram, V_p is the voltage which appears on one of the twin wires. R_c is the series combination of the probe electronic cable and the 10Ω measuring resistor in the electronics unit, and R_s is the series combination of the 100Ω resistor and the 100Ω variable resistor in the amplifier output lead. V_o is the amplifier output voltage. V_x and V_y are input terminals for oscillator signals. Amplifier IC1 has the oscillator signal applied to V_x , with V_y grounded, and amplifier IC2 has the oscillator signal applied to V_y with V_x grounded.

The purpose of the amplifier is to produce the equivalent of a very low impedance voltage source V_p at the probe wire. The obvious way to do this is to feedback the voltage V_p (through a suitable resistor) to the inverting input of the amplifier. This cannot easily be done, however, because V_p appears at the probe wire, which may be up to 100 metres from the electronic unit.

The equivalent to feeding back V_p is to feedback a combination of V_o and V_1 , which can both be measured in the electronic unit. Because R_s and R_c are much smaller than the other resistors in the circuit, the current I can be

considered to be common to them both. (The small error introduced by this assumption can be removed by a suitable procedure for adjusting R_s).

It can readily be seen that:

$$V_P = V_1 - I r_c \quad (1)$$

and also that:

$$\begin{aligned} V_O - V_1 &= I R_s \\ \therefore I &= \frac{1}{R_s} \{V_O - V_1\} \end{aligned} \quad (2)$$

substituting (2) for I in (1):

$$\begin{aligned} V_P &= V_1 - \frac{R_c}{R_s} \{V_O - V_1\} \\ \therefore V_P &= V_1 \left\{ 1 + \frac{R_c}{R_s} \right\} - V_O \left\{ \frac{R_c}{R_s} \right\} \end{aligned}$$

In the actual circuit, R_s is adjusted to be equal to $10R_c$. Then:

$$V_P = 1.1 V_1 - 0.1 V_O$$

V_1 is fed back to the inverting input and V_O to the non-inverting input through resistors selected to give the required weightings of 1.1 and 0.1.

The input resistors R_x and R_y are selected so that

$$V_P = -\frac{1}{15} V \text{ (amplifier IC1) or } V = +\frac{1}{15} V \text{ (amplifier IC2).}$$

The differential voltage applied to the twin wires by the combination of IC1 and IC2 is therefore equal to $\frac{2}{15} V$

osc. The maximum current which the amplifiers can supply is 2mA.

The current in each probe wire is detected by measuring the voltage drop across the 10 ohm series resistors R23 and R24. For each resistor, the voltage drop must be measured with a differential amplifier with an input resistance high compared with 10 ohms.

It is then also necessary to detect the difference between the 2 voltage drops in order to reject common mode signals.

In the circuit diagram, the amplifier circuit IC3 performs both of these functions. Its gain is such that approximately 1 volt p-p output signal is produced when the maximum probe current of +2 mA flows in each probe wire.

For correct operation of this circuit the 4 resistors R26, R28, R29 and R30 are matched to 0.1%. The effect of a mis-match would be to produce an output voltage when the probe is out of the water. Although this voltage would be small, it causes problems in the method used to restore calibration after changes of water conductivity.

For normal operation the switch S2a is in the OPERATE position, and the signal feeds forwards through C6 to the precision rectifier IC5 and IC6. The signal appearing at the junction of D2 and R45 is a half wave rectified version of the signal and this is converted into a full wave rectified signal of half amplitude by feeding the unrectified signal forward through the resistors R40 and R41. Exact balancing of the two halves of the full wave

signal is achieved by adjusting the BALANCE potentiometer VR3. This ensures that the ripple content of the final D.C. output signal is at a minimum.

IC6 is an inverting amplifier with smoothing provided by C7. The time constant of C7-R47 gives an output falling to 95% at 10 Hz.

IC7 is an inverting amplifier of which the gain can be varied by the SET OUTPUT control VR4. An offset derived from the power rail via R50 and VR5 makes the output zero when the probe current is 1 mA (peak). VR5 is adjusted to set the output at -10 volts with the probe disconnected and with VR4 set to its maximum.

A small signal of approximately 10% of full scale can be injected via R55 by means of the push button contacts PB1/2. This enables the corresponding recorder trace to be identified.

The output is taken to the output socket and back connector of the module, also to a centre zero balance indicator on the front panel. The indicator has a full scale range of about ± 1 volt and limiting diodes are fitted to prevent it being damaged by larger signals.

Variation of the oscillator output voltage is the method used to adjust the range of the wave probe. The correct energisation is that which causes a current of 2 mA to flow round the probe circuit when the probe is immersed to the full scale of the required range.

As the calibration of the instrument is linear, and goes through zero probes current at zero immersion, the probe current will be 1 mA when it is immersed to half of the full scale depth. The offset circuit in the precision rectifier makes the instrument output voltage go to zero under these conditions.

The method of setting the range is therefore to immerse the probe in still water to a depth of slightly more than half of the p-p maximum expected wave height. With the probe set in this position the energisation is adjusted using the SET DATUM potentiometer until the balance indicator goes to zero.

Full scale of the range is then slightly more than the expected p-p amplitude of the largest wave.

Changes of water conductivity will change the slope of the calibration line, so that the current at the original static immersion depth will differ from the 1 mA originally set. The method of restoring the calibration is therefore as follows:-

- a) Return to the original depth of probe immersion in still water, (i.e. stop the waves).
- b) If the conductivity of the water has changed since the datum was set, the balance indicator will have moved away from zero.
- c) If this is the case, the SET DATUM potentiometer is adjusted to bring the indicator back to zero. The calibration is then restored to its original value.

As has already been described, the method used for compensating for cable resistance involves making R_s (Fig. 3) equal to $10R_c$ where R_c includes the cable resistance. Because of the finite currents flowing in the amplifier input resistors, the compensation provided by doing this is not quite exact. It is also impractical to compensate by a method which involves measuring R_c and then setting R_s to an appropriate value.

A test circuit has therefore been incorporated in the electronic module to facilitate this compensation. This comprises the amplifier IC4 which is brought into operation by depressing the switch S2a into the TEST position, at the same time the zero offset of the precision rectifier is increased via R46 by the operation of switch S2b.

The test procedure is to unplug the probe connecting cable at the probe end and to plug it into the TEST sockets on the front panel instead of the connector at the top of the twin wire.

The 1K ohm resistor R34 (in parallel with the input impedance of IC4) acts as a dummy twin wire probe. Pressing the push button PB1 shunts the 1K ohm resistor with a 56 ohm resistor, and thereby changes the resistance of the dummy probe.

The amplifier IC4 is balanced, so that connection to it does not unbalance the wave probe input amplifier IC3. The output of IC4 feeds through the precision rectifier to the balance indicator as before.

The amplification through the test circuit is dependent on the setting of the SET OUTPUT control VR5 and this should always be set to maximum when adjusting the compensation. The balance indicator then nulls when the input voltage to the dummy probe is approximately 100 millivolts.

This input voltage corresponds to V_p in Fig. 2. Having connected the probe lead to the TEST input the SET DATUM potentiometer is adjusted until the water nulls.

The push button switch is then depressed to change the resistance of the dummy probe, and the compensating resistors VR1a and b adjusted until the balance indicator nulls again.

This ensures that V_p remains constant when the probe resistance changes, and therefore makes the effective source resistance of V_p equal to zero.

The lead is then removed from the test input and reconnected to the probe. The datum setting is then carried out as already described.

7 COMPONENTS LIST

7.1 Wave Monitor Module

Resistors:- All 2% metal film, Mullard MR25 or equivalent, unless otherwise stated.

Circuit Reference	Value	Circuit Reference	Value	Circuit Reference	Value
R1	10K	R21	100K	R41	2K2
R2	100K	R22	2K2	R42	10K
R3	100R	R23	10R	R43	10K
R4	100K	R24	10R	R44	2K2
R5	10K	R25	10R	R45	2K2
R6	150K	R26	4K7*	R46	100K
R7	150K	R27	10R	R47	22K
R8	10K	R28	4K7*	R48	2K2
R9	100K	R29	4K7*	R49	2K0
R10	100R	R30	4K7*	R50	22K
R11	100K	R31	120K	R51	1K
R12	10K	R32	120K	R52	10K
R13	150K	R33	56R	R53	3K9
R14	150K	R34	1K	R54	1K
R15	100K	R35	4K7	R55	220K
R16	39K	R36	47K	R56	200K
R17	47K	R37	4K7	R57	240R
R18	56K	R38	47K	R58	100K
R19	68K	R39	10K	R59	100K
R20	82K	R40	2K2		

* Matched to $\pm 0.02\%$

Capacitors

Circuit Reference	Value	Type	Tolerance (%)	Voltage
C1	220 pf	Polystyrene	10	160V
C2	220 pf	Polystyrene	10	160V
C3	0.1 uf	Polyester	20	100V
C4	1000 pf	Polystyrene	2	160V
C5	1000 pf	Polystyrene	2	160V
C6	1.0 uf	Polyester	20	250V
C7	0.22	Polyester	20	100V

Semi-Conductors

CIRCUIT REFERENCE	Type
IC1 - IC7	741TC
IC8	CA3140E
D1-D4	IN4148
ZD1, ZD2	BZY88C 5V6

Potentiometers

Circuit Reference	Value	Type
VR1	100R	81A2A-B28 A05/A05
VR2	20K	3540S-1-203 (10T, w.w.)
VR3	500R	72P (Cermet)
VR4	20K	3540S-1-203 (10T w.w.)
VR5	10K	72P (Cermet)

Misc.

M1	Level meter model Sv5
PB1	Level meter push button switch 2 No 8225A
S2	Miniature toggle DPDT 7201A
SK1-SK4,	4mm round sockets
SK5	"bnc" socket round and plug
	10 Turn dial H 507-6
	32-way plug

7.2 Power Supply Module

Resistors:- All 2% metal film, Mullard MR25 or equivalent, unless otherwise stated.

Circuit Reference	Value
R1	4.7K
R2	4.7K

Capacitors

Circuit Reference	Value	Type	Tolerance (%)	Voltage
C1	1000 uf	Electrolytic	-25, +100	63
C2	1000 uf	Electrolytic	-25, + 100	63
C3	0.22	Polyester	20	250V
C4	0.22	Polyester	20	250V
C5	0.47	Polyester	20	250V
C6	0.47	Polyester	20	250V

Semi-Conductors

Circuit Reference	Type
Recl	W01
Rec2	W01
Reg1	7815
Reg2	7815

Transformer

Circuit Reference	Type	Voltage
TFR1	ED1540	18.8

Misc.

S1	Illuminated Miniature toggle switch DPDT 10-Way plug
----	---

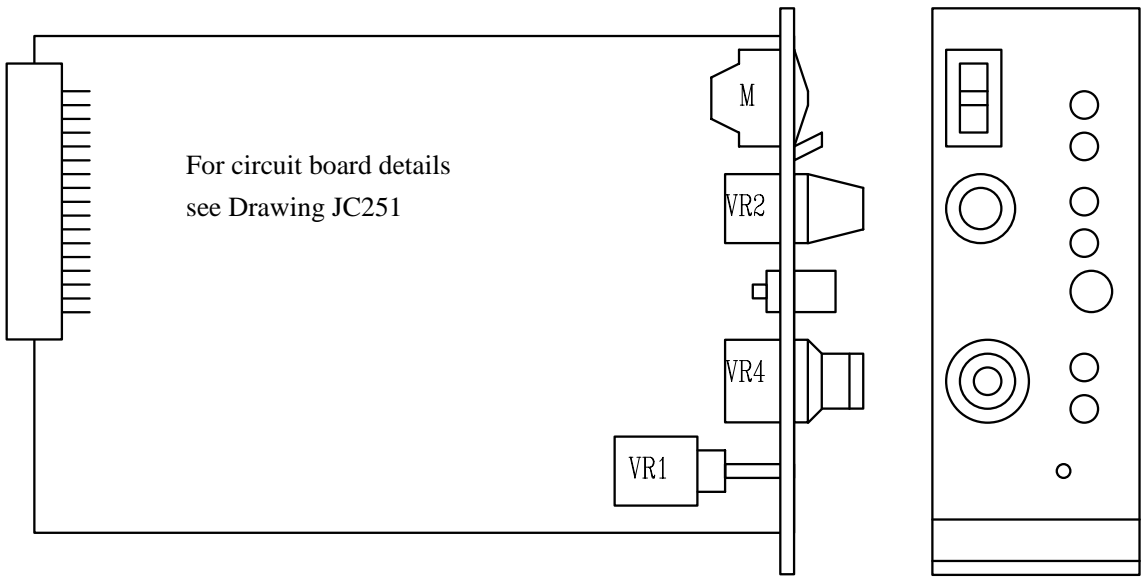

WAVE MONITOR MODULE
General Assembly

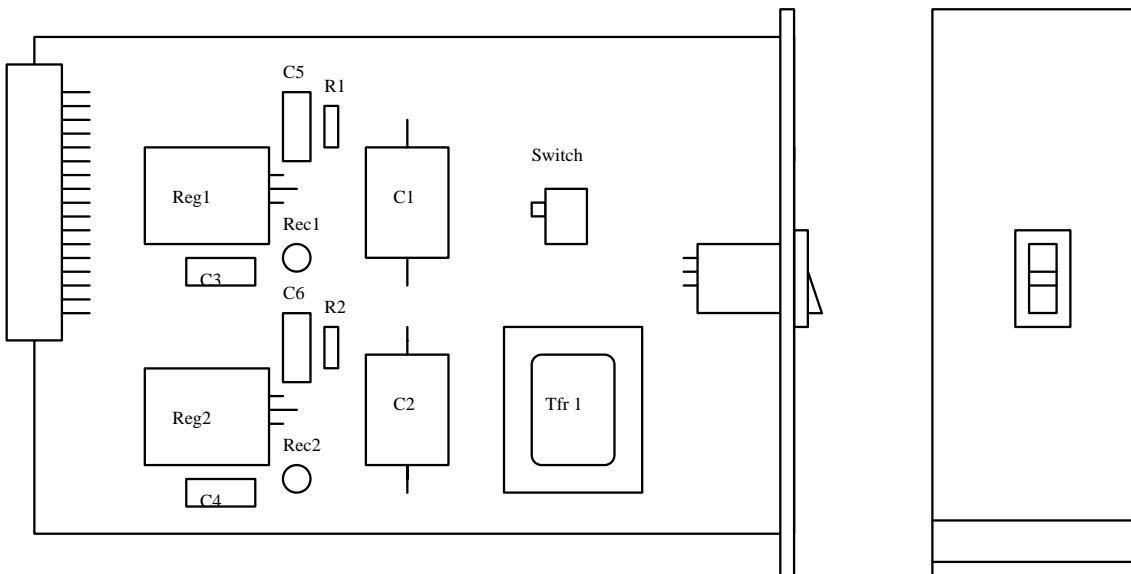

WAVE MONITOR POWER SUPPLY MODULE

General Assembly

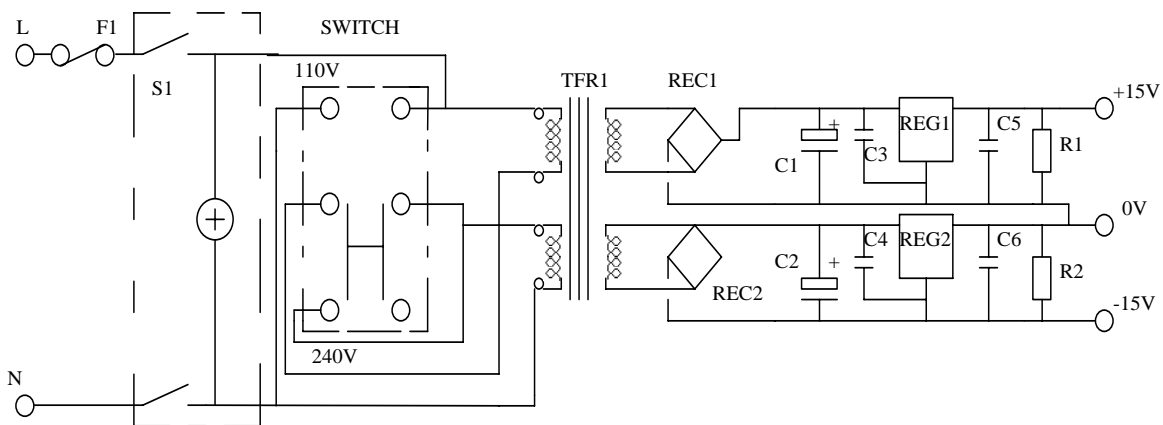

WAVE MONITOR POWER SUPPLY CIRCUIT DIAGRAM

ISSUE 2.0 15.02.96 RN