

MECHANICAL INSTALLATION

The sensor is fitted in the centre of the face opposite the display. This surface also has four 5mm mounting holes on a pitch of 110mm x 90mm. The enclosure can thus be fitted to the top of a tank, ensuring that there is a centre hole of 50mm diameter for the sensor.

MOUNTING BRACKET:

An L-shape galvanised steel bracket is available for fitting *Spencer* to a vertical wall, such as the side of a reservoir. The bracket can be attached to the wall via two 10mm holes, 100mm apart.

ELECTRICAL CONNECTIONS

WIRING

To maintain the IP rating of the head box, use a multi-core cable 6.5...8.0mm dia, and ensure the gland is fully tightened. All terminals are isolated from the case/earth. In an electrically-noisy environment it may be necessary to use a screened cable. V- should be connected to the screen. Ensure all wiring is kept away from the probe wire, since this could cause small errors in the calibration.

VOLTAGE AND/OR CURRENT OUTPUT:

If link JP1 is set to the NORMAL position, the *Spencer* will give both voltage and current outputs, derived from a DC power supply in the range 7...30V between its V+ and V- terminals. This could typically be from a 12V or 24V battery. The voltage output is produced between the Vout and V- terminals, and the current output between the V+ and Iout terminals. Both outputs can be calibrated over any range within the limits shown in the specification, but would typically be 0...5V and 0...10mA or 4...20mA.

CURRENT LOOP OUTPUT:

If link JP1 is set to the CURRENT LOOP position, the *Spencer* will operate in a 2-wire mode, where it derives its power from the signal loop. In this mode (i.e. when JP1 is set to CURRENT LOOP) the voltage output and the high and low trip outputs are disabled. The current output can be calibrated over any range within the limits shown in the specification, but would typically be 4...20mA.

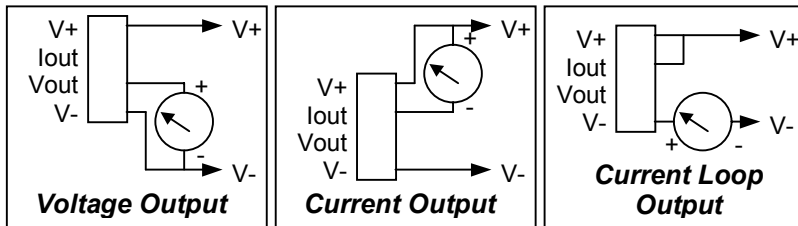

HIGH/LOW TRIP OUTPUTS:

The Winston can be equipped with two relays designated HIGH TRIP and LOW TRIP. The High Trip relay contacts close when the level exceeds a defined point, and open when it drops below the defined point less the hysteresis. Similarly, the Low Trip relay contacts close when the level drops below a defined point, and open when it exceeds the defined point plus the hysteresis. These trips are disabled in Current Loop mode (i.e. when JP1 is set to CURRENT LOOP).

CALIBRATION AND MODE SETTING

The *Spencer* display incorporates a menu system, with three pushbuttons for moving around it:

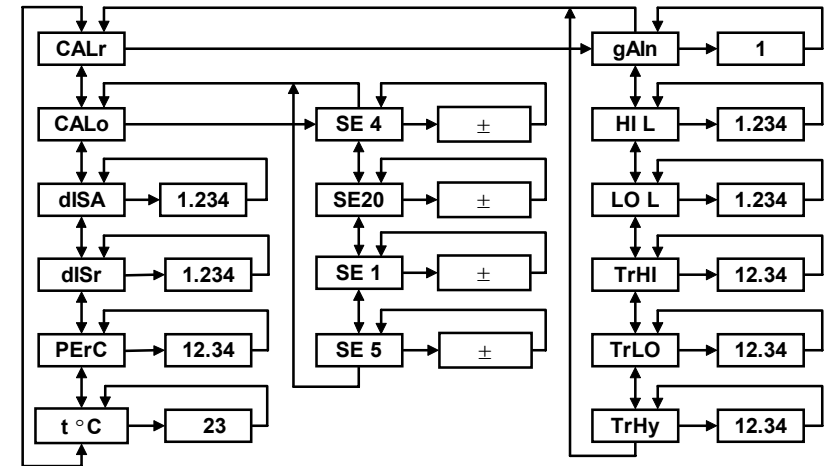

Note that the position of the decimal point gives an indication of the units of measure:

dISA shows the absolute distance from the surface, in metres. This is the default state at power-up.

dISr shows the relative distance from the surface to the Low Level reference (see **LO L**), in metres

PERc shows the distance from the surface to the Low Level reference (see **LO L**) as a percentage of the overall span (i.e. **HI L** – **LO L**).

t °C displays the measured air temperature.

CALr is used to calibrate the range requirements. Scroll right until the required digit flashes, then use the UP/DOWN buttons to change it:

gAln sets internal gain of the detector. Setting a high gain achieves the maximum range. However, at high gains the minimum distance that can be measured increases, and there is a risk of detecting unwanted echoes from unwanted objects such as the sides of a tank. These effects can be minimised by reducing the gain. Refer to the Specifications for typical settings.

HI L sets the distance of the high level from the sensor, in metres. This is the distance that will correspond to a reading of 100%.

LO L sets the distance of the low level from the sensor, in metres. This is the distance that will correspond to a reading of zero. It can be either greater than or less than **HI L**. The difference between **HI L** and **LO L** defines the span.

TrHI sets the position of the high level trip, as a percentage of span.

TrLO sets the position of the low level trip, as a percentage of span.

TrHy sets the hysteresis of both trips, as a percentage of span. The high trip will reset when the level falls to (**TrHI** – **TrHy**), and the low trip will reset when the level rises to (**TrLO** + **TrHy**).

CALo is used to calibrate the outputs. In each sub-menu state the relevant output can be read on a meter and adjusted using the UP/DOWN buttons:

SE 4 sets the current output to the value required for a reading of zero. This would typically be 4mA. If JP1 is set to Current Loop the display will show **CL 4**.

SE20 sets the current output to the value required for a reading of 100%. This would typically be 20mA. If JP1 is set to Current Loop the display will show **CL20**.

SE 1 sets the voltage output to the value required for a reading of zero. This would typically be 1V.

SE 5 sets the voltage output to the value required for a reading of 100%. This would typically be 5V.

MAINTENANCE

Since there are no moving parts, the *Spencer* does not generally require maintenance. However, if the transducer becomes contaminated with pollutants it can be gently flushed with clean water.

SPECIFICATIONS

Power requirements:	Voltage and/or current output only:	7.0...30.0VDC 2mA + current output
	If using trip level outputs:	10.0...30.0VDC 40mA max + current output
	Current loop mode: (volt drop across gauge)	7.0...30.0VDC 3.5mA minimum
Range (vertical, to level water surface):		
	Gain 0	100mm...1.5m
	Gain 1	150mm...2.5m
	Gain 2	200mm...4.0m
	Gain 3	300mm...6.0m
Response Time:	Output valid after power-up:	< 0.2 ms
	Subsequent output update rate:	< 2 seconds
Maximum Output Span:	Voltage Output:	0...10.0V
	Current Output:	0...25.0mA
	Current Loop Output:	3.5...25.0mA
Maximum Output Drive:	Current Output:	Vsupply – 5V
	Voltage Output:	2mA
Trip outputs:		Volt-free contacts rated 240VAC 1A (Subject to health and safety regulations)
Maximum voltage on any terminal relative to case earth:		240VAC
Resolution:		1mm
Accuracy:		±0.25% of maximum output span
Dimensions:		120 x 120 x 70mm, sealed to IP67

In the interest of improvement the above specifications are subject to change without notice.

Spencer



ULTRA-SONIC LEVEL GAUGE

The *Spencer* is an ultra-sonic gauge intended for measuring water depths. It is optimised for operation at sites with no mains power supply. It produces a voltage output as well as a current output, so can be used with a variety of measuring instruments. It also includes high and low level trip relays for alarm monitoring and/or local control. All functions are user-programmable via an in-built display and pushbuttons.

The *Spencer* works by emitting an ultra-sonic pulse from the transducer on the bottom of the enclosure, and measuring the time taken for the echo to be returned. A number of features are incorporated to optimise it for battery operation:

1. A valid output is produced within a very short time of applying power. This allows it to be sampled at regular intervals, and switched off between samples to conserve power.
2. It will operate from a low voltage power supply, whilst still producing a conventional 1...5V or 4...20mA output.
3. It will operate as a two-wire device, deriving its power from the 4...20mA current loop. Alternatively it can be used in three-wire mode, where the current consumption is less than 4mA.

Churchill Controls Ltd

Station Industrial Estate, Wokingham, Berkshire, RG41 2YQ

Tel: (0044) 0118-9892200 www.churchill-controls.co.uk